



Domestic energy primer
– an introduction to energy
efficiency in existing homes



energy saving trust™

Contents

1	Introduction	3
1.1	Typical energy use and improvements for different house types	4
1.2	Cost-effectiveness	6
1.3	Opportunities for energy efficient improvements	7
2	Energy efficiency measures	8
2.1	Cavity wall insulation (CWI)	8
2.2	Solid walls	9
2.3	Other wall types	13
2.4	Roofs	14
2.5	Floor insulation	18
2.6	Windows and doors	20
2.7	Ventilation	23
2.8	Heating systems	25
2.9	Boiler heating controls	27
2.10	Other central heating systems	28
2.11	Hot water	30
2.12	Lighting	32
2.13	Appliances	33
3	Renewables	34
3.1	Solar water heating	34
3.2	Wind turbines	34
3.3	Photovoltaic (PV) panels	35
3.4	Heat pumps	35
4	Building regulations and planning issues	36
4.1	Building control	36
4.2	Planning permission	36
5	Embodied energy	37
6	Cost benefit table	38
7	Relevant organisations and websites	40
8	Further reading	41

1 Introduction

This guide provides energy efficiency advisers with information on how home owners and tenants can identify opportunities for improving energy efficiency. It includes:

- Advice and recommendations for common energy efficiency improvements.
- Typical costs and savings, where appropriate.
- Issues with these improvements, and how to avoid problems.

This guide does not provide technical information on the Energy Saving Trust's best practice standards for each situation, but instead references guides where that information can be found.

Home energy use is responsible for 27 per cent of the UK's carbon dioxide (CO₂) emissions, which contribute to climate change. By following the Energy Saving Trust's best practice standards, new build and refurbished housing will be more energy efficient – reducing these emissions and saving energy, money and the environment.

The average household could save around two tonnes of CO₂ a year by making their home energy efficient.

In many instances CO₂ emissions are being reduced as a result of building regulation requirements. Building regulations require minimum levels of performance to be achieved when services, such as old central heating boilers are replaced, or when carrying out refurbishment work.

Additional improvements in energy efficiency can be achieved by choosing energy-saving improvements, such as those described in the Energy Saving Trust's best practice guidance. Not all energy efficiency improvements have to be carried out during the replacement of household services, or during refurbishment. Some can be carried out at any time – reducing running costs, emissions and improving comfort.

For an energy efficiency improvement to be viable it must be applicable to the dwelling (for example, cavity wall insulation cannot be installed in a solid-walled dwelling); ideally it should also be cost-effective.

There are a variety of factors that affect the amount of energy used, the running costs and how much CO₂ is emitted. Namely:

- Type of dwelling.
- Age.
- Location and weather.
- The existence of any energy efficiency improvements.
- The efficiency and number of appliances and services in place.
- The daily habits of the occupants.

The examples provided overleaf give an indication of how energy use tends to differ according to a dwelling's age and features (ignoring the effect of the dwelling's location and the actions of occupants).

Anyone choosing to improve the energy efficiency of their home may find it beneficial to have an energy assessment undertaken to see which improvements will have the greatest benefit.

Typical costs and savings are provided throughout this guide. A simple estimate of payback can be calculated by dividing the capital cost of the improvement measure by the estimated annual saving, using the equation:

$$\text{Payback} = \frac{\text{Capital cost}}{\text{Annual saving}}$$

Need assistance?

Explore a whole range of energy saving measures and find out about grants by contacting your local Energy Efficiency Advice Centre on 0800 512 012.

Alternatively, receive a free home energy assessment and tailored recommendations online via www.est.org.uk/myhome

Introduction

1.1 Typical energy use and improvements for different house types

Edwardian house, circa 1910	Circa 1975	New housing, post 1995
		
Where is energy used?		
 <ul style="list-style-type: none"> ■ Cooking 4 per cent ■ Space heating 63 per cent ■ Water heating 16 per cent ■ Lights and appliances 17 per cent 	 <ul style="list-style-type: none"> ■ Cooking 6 per cent ■ Space heating 44 per cent ■ Water heating 25 per cent ■ Lights and appliances 25 per cent 	 <ul style="list-style-type: none"> ■ Cooking 8 per cent ■ Space heating 33 per cent ■ Water heating 25 per cent ■ Lights and appliances 34 per cent
Carbon dioxide (CO₂)		
Emits in the region of 8 tonnes of CO ₂ per year	Emits in the region of 5 tonnes of CO ₂ per year	Emits in the region of 4 tonnes of CO ₂ per year
Original features		
<p>Typically:</p> <ul style="list-style-type: none"> • Solid walls. • Bay or sash windows with single glazing. • Open fireplaces. <p>Because of the poor levels of performance offered by these original features, the space heating costs and associated CO₂ emissions will be high.</p>	<p>Typically:</p> <ul style="list-style-type: none"> • Cavity walls. • Some loft insulation (25mm). • Double glazing. • Central heating (normally by gas boiler). <p>A gas fireplace (open fires not as common due to the Clean Air Act). Because of the above features, the overall energy use and CO₂ emissions are lower than for a solid-walled dwelling. Lights, appliances and hot water make up a progressively larger proportion of total energy use.</p>	<p>Typically:</p> <ul style="list-style-type: none"> • Insulated cavity walls. • Reasonable levels of loft insulation (150-200mm). • Floor insulation. • Double glazing. • Central heating by high-efficiency boiler (sometimes condensing). • Factory-insulated hot water cylinder. • Good heating controls. <p>Because of the above features energy used for space heating is substantially reduced. Hot water, lights and appliances make up a larger proportion of total energy use.</p>

Introduction

Edwardian house, circa 1910	Circa 1975	New housing, post 1995
Recent energy efficiency improvements?		
<p>Likely to include:</p> <ul style="list-style-type: none"> • Loft insulation (50-80mm). • The addition of a new boiler and radiators (with the fireplaces now being used as secondary heating/focal points). • Full or partial double glazing. • Draught-proofing. • New appliances. • Some low-energy lighting. <p>These additions will have reduced the bills and CO₂ emissions to some extent, but the energy efficiency of the dwelling will not be up to current standards.</p>	<p>Likely to include:</p> <ul style="list-style-type: none"> • Double-glazed windows (including draught-proofing). • Extra loft insulation (generally 100-150mm). • Cavity wall insulation (CWI). 	<p>Likely options for further reducing heating bills and CO₂ emissions include:</p> <ul style="list-style-type: none"> • Installing a condensing boiler (if not already present). • When replacing glazing, specifying BFRC rated windows of 'C' rating or above. • Upgrade to 250-300mm of loft insulation.
Most appropriate improvements		
<ul style="list-style-type: none"> • Specify a new condensing boiler. • Improve the heating and hot water controls. • Ensure that the hot water cylinder is well insulated. • Insulate the solid walls. • Add more loft insulation (up to 250-300mm). • Install low-energy lighting. • When replacing appliances, specify those that carry the energy saving recommended label. 	<p>In addition to the above, further energy efficiency improvements should be considered when perished components (e.g. windows) are being renewed.</p> <ul style="list-style-type: none"> • Specify a new condensing boiler. • Upgrade to 250-300mm of loft insulation. • Improve the heating controls. • Ensure that the hot water cylinder is well insulated. • Add floor insulation. • Install low-energy lighting. • When replacing appliances, specify those that carry the energy saving recommended label. <p>These improvements to a circa 1975 dwelling will result in substantially lower bills and CO₂ emissions than an older solid-walled dwelling (even one that has been improved).</p>	<p>In modern housing it is best to concentrate on reducing the amount of energy used for lights, appliances and hot water.</p> <p>This can be achieved by:</p> <ul style="list-style-type: none"> • Installing more low-energy lighting. • When replacing appliances, specify those that carry the energy saving recommended label. • Consider specifying renewables, especially solar hot water heating, which will substantially reduce the hot water costs.

Introduction

1.2 Cost-effectiveness

Use this table to establish the general range of cost-effectiveness for different improvement measures. (More detailed figures are contained in the cost table at the back of this guide and also against individual measures.)

	Typical payback (years)										See page
	Low cost improvements (worth tackling first)					Higher cost measures which will further reduce household bills and environmental impact					
	<1	2	3	4	5	6	7	8	9	>10	
Insulation											
Roof insulation (new installation)	■										14
Roof insulation (top up)			■	■							14
Cavity wall insulation (CWI)	■	■	■								8
Ground floor insulation (solid floor)								■	■	■	19
Ground floor insulation (timber floor)			■	■	■						18
Internal wall insulation							■	■	■	■	9
External wall insulation							■	■	■	■	11
Windows and doors											
Windows achieving a BRFC rating in band C or above*					■	■					20
Secondary glazing								■	■	■	21
Insulated doors*										■	21
Heating and hot water											
A-rated condensing boiler*	■										25
Upgrade cylinder insulation	■	■									30
Replace hot water cylinder with high-performance model			■	■	■						31
Full heating controls package				■	■	■					27
Ventilation											
Seal any disused fireplaces	■										
Draught-stripping and sealing						■	■				21
Lights and appliances											
Energy efficient lighting	■	■	■								32
A-rated white goods	■	■	■								33

*Marginal cost. The additional cost of specifying a more energy-efficient option to work already being undertaken e.g. an A-rated condensing boiler, as opposed to a B-rated one.

Notes

- The costs and savings figures will vary according to the size of the dwelling, its location, the measures (if appropriate), fuel, heating system and the materials used.
- Energy savings are estimated from a range of standard house types with gas central heating and standard occupancy. Actual savings depend on individual circumstances. Remember that some of the benefit may be taken in improved comfort.

Introduction

1.3 Opportunities for energy efficient improvements

As stated earlier, when undertaking home improvements there is often the opportunity to specify improved levels of energy efficiency. For example, when installing a new kitchen you could choose to install low-energy lighting and appliances. This table notes some of the possible opportunities. Please refer to the pages identified for more information on each measure.

Boxes marked ■ indicate good opportunities for cost-effective energy efficiency improvements. Boxes marked ■ indicate other opportunities that are well worth considering.

Measures to consider	Opportunity																
	Moving into a new 'existing' home	Extensions	Loft conversion	Nursery	New kitchen	New bathroom	Adding a conservatory	Re-roofing	Re-plastering	Replacing windows	Re-wiring	Re-flooring	New heating system	Replacement boiler	Replacing hot water cylinder	Decorating	Re-render externally
Wall insulation	■	■	■	■	■	■	■	■	■	■	■	■	■	■	■	■	■
Roof insulation	■	■	■	■	■	■	■	■	■	■	■	■	■	■	■	■	■
Floor insulation	■	■	■	■	■	■	■	■	■	■	■	■	■	■	■	■	■
Efficient heating and controls	■	■	■	■	■	■	■	■	■	■	■	■	■	■	■	■	■
Efficient hot water system	■	■	■	■	■	■	■	■	■	■	■	■	■	■	■	■	■
Draught-stripping	■	■	■	■	■	■	■	■	■	■	■	■	■	■	■	■	■
Ventilation	■	■	■	■	■	■	■	■	■	■	■	■	■	■	■	■	■
Windows	■	■	■	■	■	■	■	■	■	■	■	■	■	■	■	■	■
Energy efficient lighting	■	■	■	■	■	■	■	■	■	■	■	■	■	■	■	■	■
Energy efficient appliances	■	■	■	■	■	■	■	■	■	■	■	■	■	■	■	■	■
Check if building regulations apply ¹	✓	✓	✓				✓	✓	✓	✓	✓	✓	✓	✓	✓	✓	✓

¹This column is only a guide. The technical performance requirements, definitions and procedures for building regulations vary across the UK (see page 36). Other building works and improvements may also need to comply with building regulations. For example, in Scotland, altering the ventilation arrangements may require approval.

Important notes

- All energy efficiency measures may be worth considering.
- Some home improvements are subject to statutory regulations which set minimum standards.

2 Energy efficiency measures – insulation

Costs and paybacks

Some improvements described in this guide are accompanied by indicative savings for a typical gas heated semi-detached dwelling. These figures are provided to aid comparison of the different energy efficiency measures available. They are not intended to be representative of every scenario, because the costs and savings will vary from region to region, in accordance with the type of dwelling and the occupants' habits.

The installed costs per measure for insulation improvements are representative of the typical cost to the householder in a subsidised scheme e.g. Energy Efficiency Commitment (EEC) via an energy supplier or local authority. Further cost and payback information is provided at the back of this guide.

Identifying a cavity wall

- Cavity walls are built using two skins of bricks, or brick and blockwork, with a cavity (gap) in between.
- A brick cavity wall usually has the bricks placed lengthways (stretcher bond).
- The walls are held together using either metal or, more recently plastic, wall ties.
- The cavity is normally 50-60mm wide.

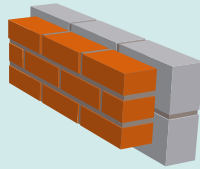

An injection hole prior to filling



Insulation being injected into the wall

Further information

- Cavity wall insulation in existing housing (CE16/GPG26)
- Cavity wall insulation: unlocking the potential in existing dwellings (GIL23)

2.1 Cavity wall insulation (CWI)

Most cavity walls can be filled. Dwellings built after the early 1980s normally incorporate wall insulation as standard.

	Typical
Annual saving	£130-160
Installed cost	around £260
Installed payback	less than 2 years

For the occupier, the benefits of CWI include cheaper fuel bills and greater comfort, with heat loss through walls being reduced by up to 60 per cent. After loft insulation, CWI is the most cost-effective insulation measure. Installing wall insulation when replacing a new heating system is a great idea because it reduces heat loss and thus potentially allows a smaller and cheaper heating system to be specified.

Installing CWI usually takes less than half a day and the occupants can remain in the dwelling. The work should be carried out by a specialist contractor who can provide a CIGA (Cavity Insulation Guarantee Agency) guarantee, or in the case of injected polyurethane, a manufacturer's guarantee.

Before the insulation is installed a pre-installation inspection is undertaken to assess the wall's suitability – including exposure of wall to driving rain, masonry materials used, pointing of the masonry. It is recommended that cavities of less than 50mm should not normally be filled. Any defects or dampness problems should be put right before work begins. If this is satisfactory, the installation process proceeds as follows:

- Injection holes are drilled through the mortar joints at 1m intervals.
- Cavity barriers are installed to prevent the fill entering the cavities of adjacent properties.
- Air ventilators that cross the cavity are sleeved (or sealed, if obsolete).
- The insulant is injected into the wall cavity.
- Quality checks are carried out on the fill material prior to making good the injection holes.
- Injection holes are filled with colour-matched mortar or render.

The National Insulation Association holds a register of proven systems and installers. (Please see 'Relevant Organisations and websites' at the back of this guide.)

Energy efficiency measures – insulation

2.2 Solid walls

The heat lost through an uninsulated solid wall is typically more than double that of an uninsulated cavity wall.

A solid wall can be insulated either internally or externally – either option will greatly increase comfort, while also reducing running costs and associated environmental impact.

2.2.1 Internal insulation

Internal insulation typically consists of either dry lining in the form of a laminated insulating plasterboard (known as rigid insulation board), or a built-up system using insulation between a studwork frame.

	Typical
Annual saving	£270 -£340
Installed cost	from £40/m ²

Insulated studwork

The insulation is held between a metal or, preferably, timber framing system and finished with a vapour control layer and plasterboard. This approach allows a variety of insulation thicknesses to be installed. Fibre-based insulation will typically require in excess of 120mm to achieve best practice performance.

For small dwellings, where internal space cannot be sacrificed, a high performance rigid insulation board solution may be preferable.

Rigid insulation board

Rigid insulation boarding is a composite board made of plasterboard with a backing of insulation. The insulation backing can be specified in a variety of thicknesses. Insulation in excess of 60mm will typically be required to achieve best practice levels of performance. Up to 100mm of insulation can be included. Rigid insulation boards are usually fixed to the wall surface using continuous ribbons of plaster or adhesive, plus additional mechanical fixings.

The joins between the boards should be lapped and sealed to help prevent air leakage. Almost all brands of rigid insulation boarding provide better insulation than comparable thicknesses of fibre-based insulation (such as mineral wool). It is therefore possible to achieve the same thermal performance using reduced thicknesses of insulation (which can be a major asset for small dwellings).

Before rigid insulation boarding is installed the surface of the wall must be carefully prepared. Where existing plaster is removed and the brick is uneven, the wall must be levelled using render to provide an even surface for fixing.

Identifying a solid wall

- Solid walls are made mainly of brick or stone.
- Bricks are placed head-on and lengthways (such as Flemish and English bond types).
- Solid brick walls are usually 220-225mm thick; more so for stone walls.
- Most pre-1930 dwellings have solid walls.

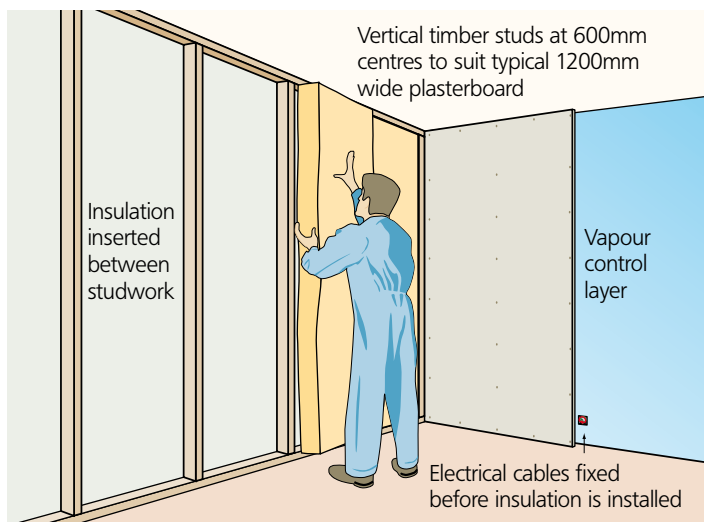
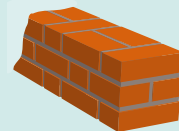

Fitting insulated studwork

What sort of insulants are used in rigid insulation boards?

The Energy Saving Trust guide 'Insulation materials – thermal properties and environmental ratings' (CE71) should be consulted. Common insulants include polystyrene, polyurethane and phenolic foam.

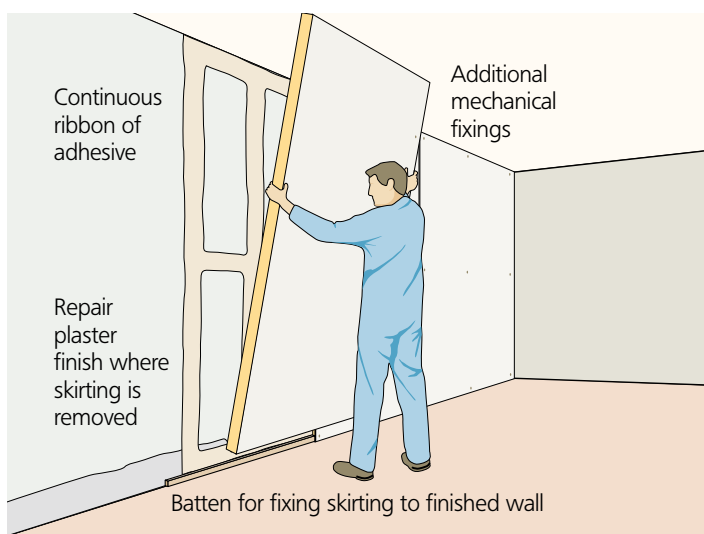

Fitting rigid insulation board

Energy efficiency measures – insulation

Combined dry-lining methods

A combination of both insulated studwork and rigid insulation board (instead of just finishing off with ordinary plasterboard) can be used to increase the thermal performance and further reduce running costs.

This method can be especially advantageous where the internal wall face is uneven because time spent preparing the internal wall face is reduced. The combined method also helps reduce thermal bridging.

Flexible thermal linings

Flexible thermal linings are rolls of thin (typically 10mm) insulation which can be applied internally to solid walls before wallpapering, tiling or painting.

Although flexible thermal linings do not achieve the thermal requirements of building regulations, or the associated financial savings of other internal insulation methods, they are useful when full refurbishment is not an option or required by the building regulations.

The most cost-effective time to have internal insulation installed is during a major renovation or when:

- The existing plaster is being renewed.
- Existing services (e.g. electrical cables, plumbing and central heating) and fittings (e.g. kitchen units and sanitary fittings) are being replaced.

It is important to ensure that the wall is not suffering from damp or weather penetration prior to selecting this insulation strategy. Internal insulation should not be used to isolate dampness.

Internal insulation:

- ✓ Is cheaper than external insulation.
- ✓ Is suitable for experienced DIY enthusiasts.
- ✓ External wall appearance is maintained.
- ✓ Easier to install and maintain than external cladding.
- ✓ Room surfaces warm up quickly, so internal insulation is well-suited to houses heated only in the morning and evening.
- ✗ Can leave thermal bridges.
- ✗ Fixing of heavy items can be more difficult (although special fixings can be purchased).
- ✗ Reduced room size can be critical in small rooms.
- ✗ Skirting boards, door frames and electrical fittings need to be re-positioned.
- ✗ Disruptive to the tenants.

Further information

- Internal wall insulation in existing housing (CE17/GPG138)
- Refurbishment guidance for solid walled houses (CE184/GPG294)

Energy efficiency measures – insulation

2.2.2 External insulation

External insulation systems are made up of an insulation layer fixed to the existing wall (using a combination of mechanical fixings and adhesive, depending on the insulation material used) and a protective render or cladding finish.

Typical	
Annual saving	£290-£350
Installed cost*	from £1800
Installed payback	5-6 years

*This is a marginal cost, if the walls are being repaired anyway.

Wet-render systems

Most external renders consist of either thick sand/cement render applied over a wire mesh, or a thinner, lighter polymer cement render applied over a 'GRP scrim'. A 'pebbledash' render should need less maintenance than a painted render finish.



Wet render finish



Pebble dashing

External wall insulation systems are not recommended for dwellings where the walls beneath are structurally unsound or cannot be repaired.

Select a system that has been approved by an appropriate independent technical approvals authority.

The Insulated Render and Cladding Association (INCA) holds a register of proven systems and installers. (Please see 'Relevant Organisations and websites' at the back of this guide.)

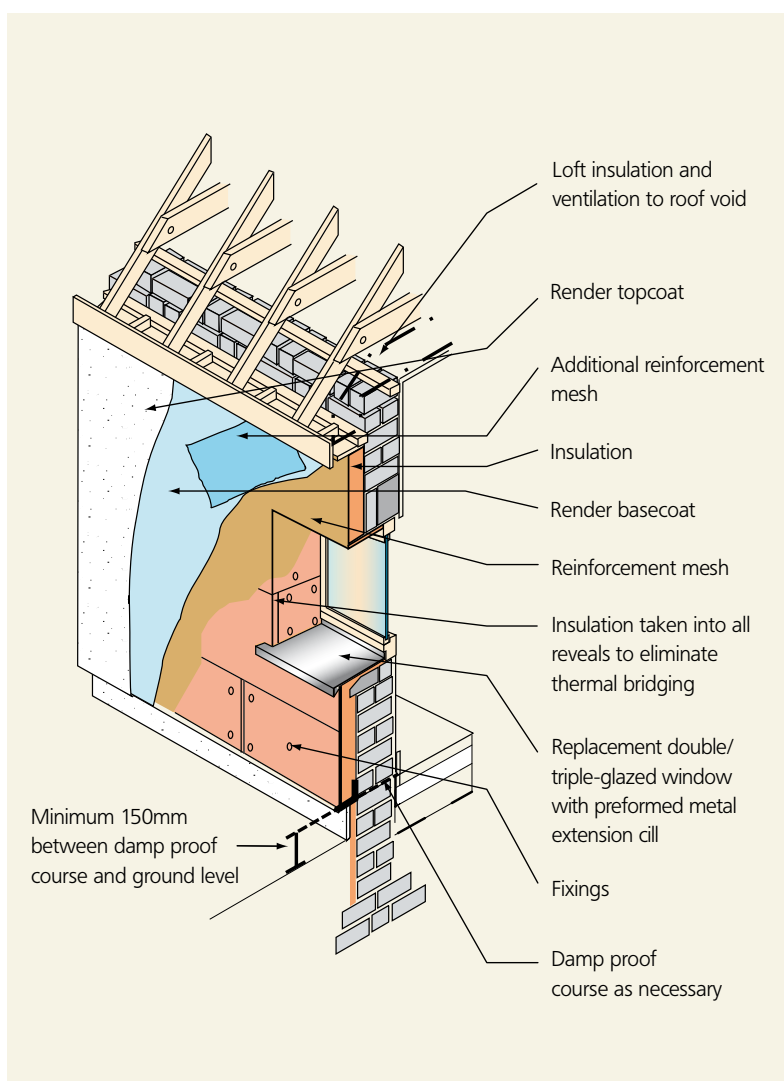

Energy efficiency measures – insulation

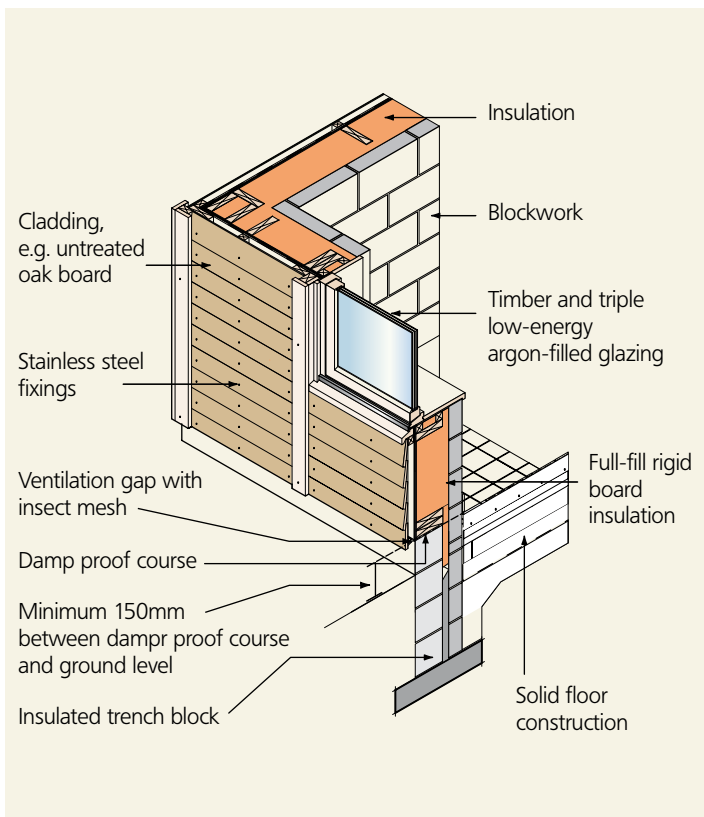

Dry-cladding

Many tenants find dry-cladding to be more aesthetically pleasing because of the different cladding materials that can be used, including:

- Timber panels.
- Stone or clay tiles.
- Brick slip.
- Aluminium panels.

The drawback of dry-cladding systems is that they can be relatively expensive compared to wet render systems.



Brick slip cladding

External insulation:

- ✓ Can significantly reduce running costs.
- ✓ Is easy to install and can be applied without disruption to the tenants.
- ✓ Renews aging façades and increases the life expectancy of the building.
- ✓ Large amounts of insulation can be used without reducing living space.
- ✓ Improves the airtightness of the construction, which reduces draughts.
- ✓ Reduces thermal bridging, minimising condensation and heat loss.
- ✓ Room surfaces heat up slowly, so it is better for homes that are heated all day.
- ✓ Helps to alleviate problems such as internal damp or water ingress.
- ✗ Cannot be undertaken as a DIY project – must be installed by a specialist contractor.
- ✗ Can have long payback times, unless installed in conjunction with other remedial work and refurbishment works.
- ✗ Unless the dwelling is already rendered, adding external wall insulation will dramatically change the external appearance of the dwelling and planning permission may be required.
- ✗ Not suitable for listed, historic or properties with fine architectural detailing.
- ✗ Vulnerable areas need to be protected because damage can lead to damp and weathering problems.
- ✗ May require alteration to rainwater goods and sills.

Further information

- Internal wall insulation in existing housing (CE17/GPG138)
- External insulation systems for walls of dwellings (CE118/GPG293)
- Refurbishment guidance for solid walled houses (CE184/GPG294)

Energy efficiency measures – insulation

2.3 Other wall types

A variety of other common wall constructions can also benefit from additional wall insulation; however, specialist advice should be sought and each dwelling treated on a case-by-case basis.

Timber-framed dwellings

All timber-framed dwellings constructed in the UK after 1976 (or 1977 for Northern Ireland) are insulated to a reasonable thermal standard. However, there are some 100,000 early examples of timber frame dwellings in existence (all pre-1976) which are either uninsulated or poorly insulated.

Insulating internally using a rigid insulation board dry-lining is a common solution used during whole house refurbishment work.

It may also be possible to insulate between the stud frame. However, both options require professional guidance to avoid problems.

Non-traditional methods of construction

There are many other non-traditional buildings that can benefit from wall insulation, such as:

- Wimpey no-fines (cast in-situ concrete).
- Airey (pre-cast concrete).
- BISF (steel framed).

For cast in-situ and pre-cast concrete walls (in sound condition) external insulation can be used. Internal insulation is also an option, but generally not as preferable due to problems with cold spots (also known as thermal bridging).

Steel frame systems, such as British Iron and Steel Federation (BISF) dwellings can be insulated externally or internally using either mineral wool or rigid insulation board dry-lining. This is a specialist job because it is important to avoid any condensation problems, which would otherwise cause the degradation of these early non-galvanised steel frames.



Jackson timber frame house



Oakridge development – light gauge steel frame panellised construction
(photo courtesy Sentinel Housing Group)

Energy efficiency measures – insulation

2.4 Roofs

The main types of roof are:

- Pitched roofs with lofts.
- Pitched roofs with attic rooms.
- Flat roofs.

Lofts are the easiest to insulate – either insulating between the joists, or at roof level in the rafters. Attic rooms and flat roofs can be insulated, but the work is best done during a conversion or major renovation.

The optimum depth for loft insulation is 250-300mm; anything less than this should be topped up. (Please also note, however, that there is no credible benefit of using more than 300mm.)

Mineral wool quilts are generally used for this purpose – the insulation being laid both in-between the joists and over the joists. Laying insulation over the joists has the additional effect of reducing the amount of heat which is conducted through the timber joists.

Roof insulation can reduce heating costs in most house types by up to 20 per cent – more so, if there is no existing insulation.

Best undertaken by professionals; however, DIY enthusiasts can consider doing it themselves – provided that a breathing mask, protective clothing and gloves are worn to prevent irritation.

Loose fill material, such as cellulose, can also be used. Loose fill material should only be installed by a specialist National Insulation Association contractor (Please see 'Relevant Organisations and websites' at the back of this guide).

When fitting insulation between the joists ensure that a continuous line of insulation is laid down to the eaves and into any tight corners. The insulation should not be compressed to any great extent, because this reduces its performance. If the occupants wish to use the loft as a storage space, insulating the rafters may be a more appropriate solution.

2.4.1 Insulating between joists to 300mm

	Typical	
Existing depth	0mm	50mm
Annual saving	£180-220	£50-60
Installed cost	£230	£240
Installed payback	around 1 year	4-5 years

Alternatively, use 100mm of mineral wool between the joists, and then use rigid insulation board (and additional hardboard for heavy items/walkways, as necessary) on top of the joists for a small proportion of the loft space. This will provide a storage platform, while still maintaining good levels of insulation throughout.

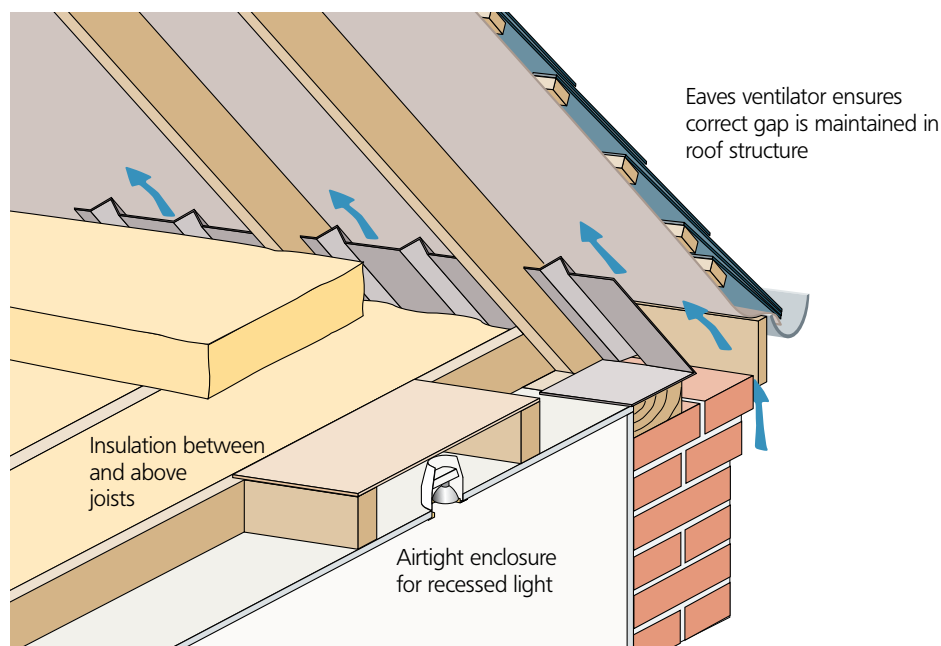

Energy efficiency measures – insulation

When insulating between joists

DO:

- ✓ Insulate and draught-proof the loft hatch, or buy a proprietary new one.
- ✓ The extra insulation makes the loft space colder – so insulate around (but not beneath) water tanks and pipe work to prevent freezing.
- ✓ Provide a safe walkway from the loft hatch to any cold water tanks (see below).
- ✓ Fill all holes at ceiling level, especially where pipes pass through the loft from a bathroom or airing cupboard. This prevents moist air condensing on cold surfaces in the loft.

Note: If work to the heating system is being undertaken, consider installing a mains pressure system as this removes the need for a cold water cistern in the loft.

DON'T:

- ✗ Block ventilation openings into the loft from the eaves, as ventilation is required to reduce the risk of condensation.
- ✗ Install recessed light fittings in the ceiling beneath the loft unless they are sealed or boxed in accordance with manufacturers guidance – warm air can enter the cold roof space and cause damage due to condensation.
- ✗ Run electric cables or recessed lighting beneath the insulation. Existing cables should be routed above the insulation where possible to prevent fire risk.

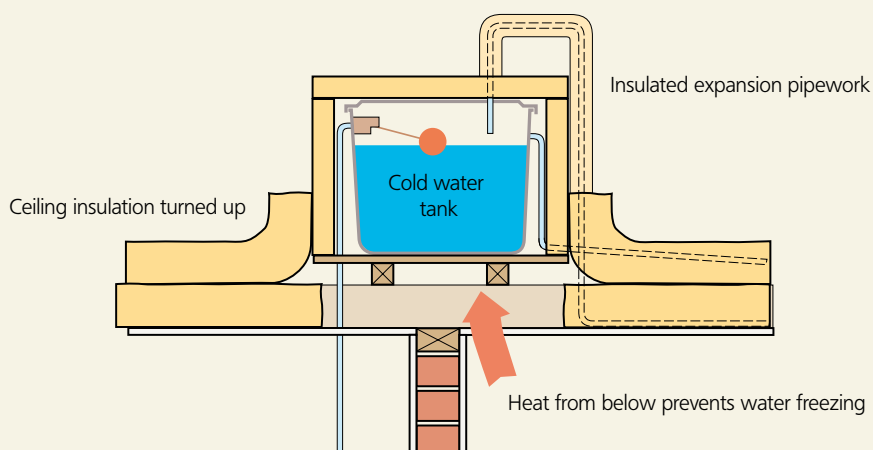

Energy efficiency measures – insulation

2.4.2 Insulating rafters

Although it can be done at any time, insulating at rafter level is most cost-effective when converting a loft or when re-roofing. Ventilated roofs can be insulated by experienced DIY enthusiasts; sarking insulation should only be installed by a specialist.

Attics can be insulated from the inside (ventilated roof) or from the outside (sarking insulation). To achieve best practice levels of performance insulation will need to be both between and over the rafters.

Ventilated roof construction

The insulation is located towards the inside of the rafters with a ventilation space of at least 50mm between the insulation and the sarking felt. Ventilation from eaves to eaves over the attic room is required. For roof pitches over 35 degrees, ventilation is also needed at the ridge.

The vapour control layer that is required behind the plasterboard lining on the sloping part of the ceiling should not be broken by making holes for services.

If the rafters are not very deep, consider insulating over the rafters using rigid insulation boarding, this will allow a more practical thickness of insulation to be installed between the rafters.

Sarking insulation

Insulation is fitted towards the outside of the rafters, without the need for ventilation or a vapour control layer.

A number of proprietary systems are available. These use mineral wool and thermal boards. It is only an option when the roof covering is being replaced.

Insulating other areas of an attic

Insulation to the vertical part of the attic is normally achieved using mineral wool or rigid insulation boards, friction-fitted between the timber studs.

Rigid insulation board is a convenient way of adding insulation to dormer sides.

Further information

- Energy efficient refurbishment of existing housing (GPG155/CE83)
- Energy efficient loft conversions (CE120)

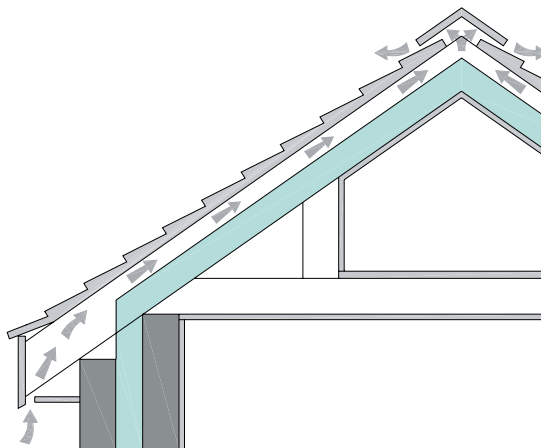

Ventilated roof construction

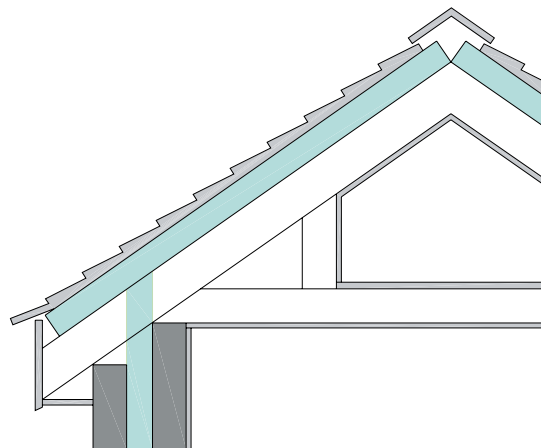

Sarking insulation

Energy efficiency measures – insulation

2.4.3 Flat roofs

If the existing roof is flat then there are several options and opportunities for adding insulation. The waterproof covering of flat roofs has a limited life, usually between 15-20 years.

Insulating a flat roof should only be carried out by a specialist roofing contractor. The best way to insulate a flat roof is above the roof deck (the boarding on top of the timber joists). The insulation can be either between the roof deck and weatherproof covering (sandwich method), or on top of the weatherproof covering (inverted method).

Warm deck method

- Suitable when the roof covering, and possibly the roof deck, need to be replaced.
- The new weatherproof covering needs to be finished in white chippings or solar reflective paint to stop it overheating in the sun.
- Ventilation of the space between the timber joists is not required.
- A high-performance vapour control layer must be bonded or mechanically fixed to the deck with joints sealed in hot bitumen.
- Polyurethane, polystyrene and high-density mineral wool can be used.

Inverted method

- Insulation needs to be weighted down with 'ballast' to stop it being lifted by the wind.
- Ballast is normally paving slabs, pebbles or cement topping to the insulation.
- Existing timber roofs are not normally strong enough to support the extra weight.
- Extruded polystyrene and polyurethane are common insulation materials.

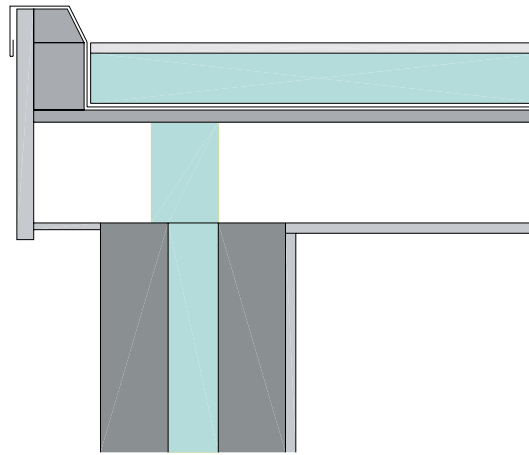

Warm deck

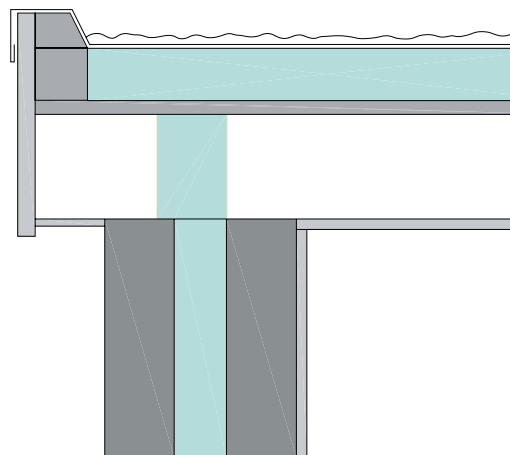

Inverted

If a flat roof is perished, consider changing to a pitched roof incorporating more insulation – pitched roofs require less maintenance and can be more aesthetically pleasing.

Energy efficiency measures – insulation

2.5 Floor insulation

Ground floor insulation is most effective for detached houses because most heat is lost along the perimeter of the floor.

Heat loss through floors can be reduced by up to 60 per cent by insulation.

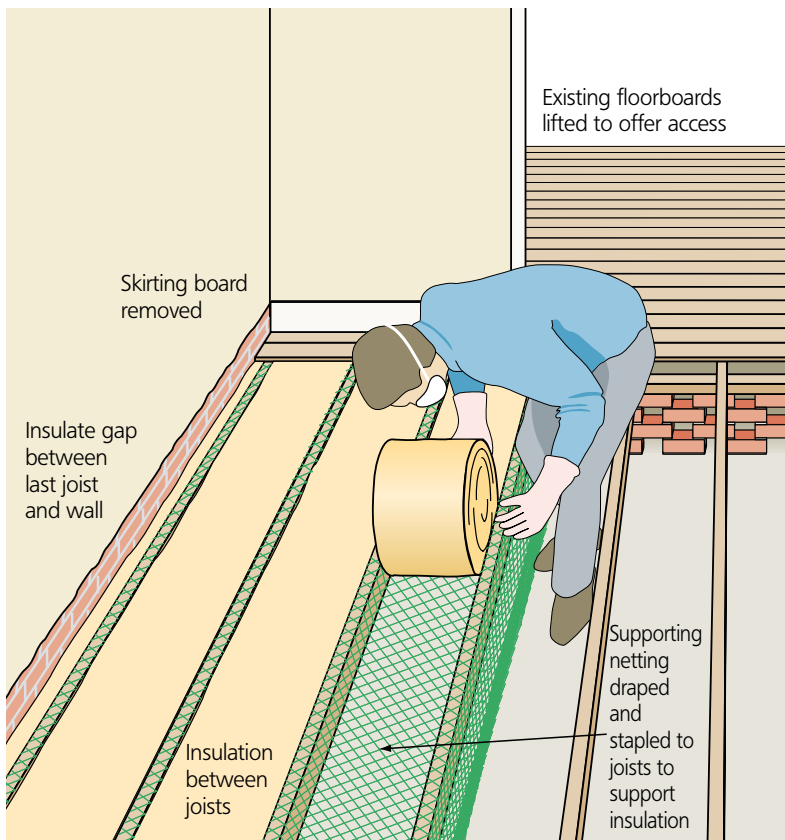

2.5.1 Timber floors

Typical	
Annual saving	£40-50
Installed cost	from £100 for materials
Installed payback	less than 3 years

Insulating timber floors is most cost-effective when the floorboards need to be lifted (e.g. to run pipes or wiring, or to deal with rot) or if there is access from below (e.g. from a basement).

Mineral wool quilts (100mm or more), rigid insulation boards or blown insulation are commonly used.

Mineral wool quilts are held in place using netting. Rigid insulation boards are fixed using nails.

The underfloor void needs to be well ventilated to prevent the formation of condensation.

It is also possible to lay rigid insulation on top of the existing floor to further improve performance – although this will have the effect of increasing the floor height (see solid floor guidance).

Insulating timber floors:

- ✓ Can be undertaken by an experienced DIY enthusiast (except for blown polyurethane insulation).
- ✓ Cuts out draughts and increases comfort.
- ✓ Easy to do if accessible from an unheated basement.

Energy efficiency measures – insulation

2.5.2 Solid floors

The most common method of insulating an existing solid, suspended 'beam-and-block' or 'raff' floor is to insulate on top using a rigid insulant such as expanded polystyrene, polyurethane or phenolic foam.

Chipboard, or other suitable board finish is placed on top of the insulant to provide a floor deck.

- Any existing chipboard, or flooring, must be removed before laying the insulation (as it could rot).
- The surface of the concrete slab must be flat and free from plaster and mortar droppings to ensure that the insulation boards above the slab do not 'rock' during walking.

Insulating solid floors:

- ✓ Can help to reduce cold draughts and air leakage.
- ✓ Placing insulation above the concrete slab helps the room to warm up quickly when the heating is switched on.
- ✗ Will raise the floor level.
- ✗ Skirting boards need to be removed and re-fixed and doors will need to be shortened.
- ✗ Can cause problems with unequal heights at staircases and external doors.

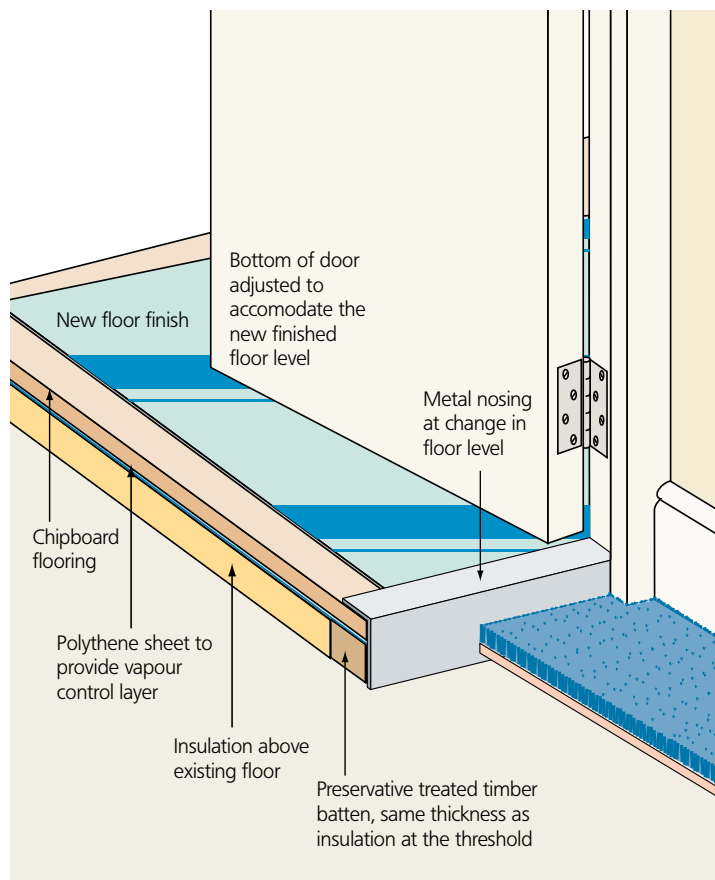

Insulating solid floors

Further information

- Refurbishment guidance for solid walled houses (CE184)
- Energy efficient refurbishment of existing housing (GPG155)

Energy efficiency measures – windows and doors

2.6 Windows and doors

A major source of energy loss is through windows and doors.

Energy-efficient windows, when correctly selected and installed, will help to minimise the heating costs and will also increase comfort.

Although savings from installing new windows are not as high as other measures (e.g. cavity wall insulation), it is important to recognise that windows are replaced very infrequently so another opportunity to install high-performance glazing may not arise for a number of years.

Secondary glazing is a good option where thermal performance needs to be improved and the existing character of the dwelling needs to be maintained.

Draught-stripping of existing badly fitting windows and doors is inexpensive and simple to install. It can greatly improve comfort as well as reducing heat loss.

2.6.1 New windows

When replacing windows, high-performance units should be specified as follows:

- Ideally, they should achieve a BFRC rating in band C.
- The 'energy saving recommended' logo will also be present on windows in band C and above (please see page 33).

Payback by specifying a BFRC rated C window, as opposed to E, is usually achieved within 5 to 6 years.

Replacement windows should always be fitted by a reputable installer and sealed around the frame (to reduce draughts and air leakage at the wall-to-frame junction). In England, a FENSA registered installer should be used (please see 'Relevant organisations and websites').

Replacement of windows in historically sensitive buildings should only be undertaken after consultation with the local authority's building conservation officer.

Typical features of high-performance windows and doors include:

Double or triple glazing

The number of panes and the width of the air gap influence the performance (i.e. U-value). The gap between panes should be in the region of 16mm or more (unless gas filling is used).

Low-e coating

This is a special coating on the inside of the inner pane which is applied during manufacturing. It helps to reflect radiant heat back into the room.

Gas filling

Instead of being filled with air, the gap between panes can be filled with argon, krypton or xenon. Filling the gap with one of these gases instead of air reduces the amount of heat that is conducted through the window. Xenon is the most effective, but argon is the cheapest and most widely available.

Insulated window frames

Heat loss occurs through the window frame as well as through the glass. An insulated frame further reduces heat loss and improves comfort.

Draught-stripping

The use of compression seals reduces air leakage around the frame.

With both primary and secondary glazing, allowance should be made for safe cleaning and escape through the window, in case of fire.

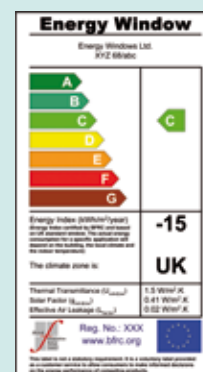

BFRC Rating

The BRFC rating allows comparison of different window types.

The rating takes into account the amount of heat lost transmitted through the window, as well as how much air leaks into or out of the window unit when it is closed.

Energy efficiency measures – windows and doors

2.6.2 Secondary glazing

Secondary glazing is normally made of glass in aluminium or plastic frames; flexible plastic glazing can also be used.

- Can be installed by competent DIY enthusiasts or a builder.
- Fairly economical and permanent.
- Can provide effective sound insulation if the panes are 150mm or more apart.
- To avoid condensation only the inner pane of the secondary glazing is draught-proofed (indeed for secondary glazing, it is good practice to vent the gap between the glazing units to external air).

2.6.3 New doors

Replacement doors, whether unglazed or half-glazed, should have insulated cores i.e. insulation between the two outer surfaces.

Insulated doors are available which achieve U-values as low as 0.6W/m²K. Insulated doors have an insulating core of polyurethane sandwiched between an outer skin (various materials available).

2.6.4 Draught-stripping

	Typical
Annual saving	around £20
Installed cost	from £75
Installed payback	around 4 years

Badly fitting doors, windows and loft hatches are all major sources of heat loss. Draught-stripping is inexpensive and simple to install and can greatly improve comfort as well as reducing fuel costs.

An accurate estimate of potential fuel savings due to the fitting of draught-proofing is difficult, but the benefits are quickly realised – mostly in terms of comfort.

- ✓ Draught-proofing is inexpensive.
- ✓ Easy DIY job.

Improved savings can be made by also sealing unwanted gaps and cracks in the building fabric, in addition to draught-proofing doors, windows and loft hatches. However, these should only be tackled after carrying out a pressure test.

Please see 'Improving airtightness in dwellings' (CE137/GPG224).

Compression seals

Compression seals are particularly well suited for external doors as the initial 3mm of the draught-stripping allows for seasonal movement of the door.

There is a wide variety of synthetic rubbers which offer good performance (including EPDM and silicone seals), sheathed foam or nylon brush, with rigid PVC-U or aluminium carriers nailed or screwed to the frame of the door. Care may be needed when painting to avoid damage to brushes and some types of rubber.

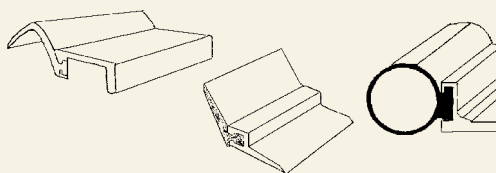

An example of compression seals

Low-friction or wiper seals

Suitable for most doors and window types. Wiper seals are generally made of nylon brush pile; are self-adhesive; and available in a variety of pile heights for different gaps. They are especially good on sliding windows and doors, but need special care when repainting.

Rubber blade wiper seals are good for wooden doors and casement windows. Some types are suitable for sliding applications.

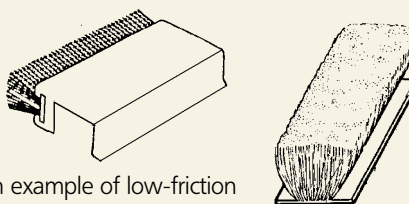

An example of low-friction or wiper seals

Gun-applied sealants and fillers

Larger gaps, including those at the heads of windows, can be filled using silicone or polyurethane sealants which, when correctly applied, expand, set and harden to permanently fill the gap.

Gun-applied sealants require careful application to be effective. Consult 'Improving airtightness in dwellings' (CE137/GPG224) for further information.

Energy efficiency measures – windows and doors

Helpful tips

- Doors are a major source of draughts and should be draught-proofed as a priority.
- Letter boxes should be fitted with a letter box cover to reduce draughts.
- Use of lined curtains, blinds and shutters can help keep in the heat and prevent draughts.
- Loft hatches should be sealed to prevent warm moist air entering the roof space, resulting in possible condensation and rot.
- Boarding out or using a thick underlay on timber floors can reduce draughts.

Point to watch

Adequate permanent ventilation **MUST** be provided to permit the entry of combustion air for all open-flued heating and hot water appliances, including open fires. After any draught-stripping or sealing work, safe operation of all open-flued appliances should be checked. Please see 'Choosing a heating installer' on page 26 for guidance.

Further information

- Energy efficient refurbishment of existing housing (CE83/GPG155)
- Windows for new and existing housing (CE66)

Condensation problems?

Common causes of condensation include:

- Human activities, such as cooking and showering, washing and drying of clothes, which release large amounts of water vapour.
- The absence of purpose-provided ventilation, such as extract fans or occupants not opening windows during activities such as showering, or cooking, to remove the excess water vapour.
- Inadequate heating and insulation – if indoor temperatures and surfaces are not maintained above the 'dew point' temperature, water will condense out of the air and form surface condensation and damp, which can lead to mould growth.

Installing local extract fans, having an efficient heating system and adding extra insulation will remove the problem in most cases.

Energy efficiency measures – ventilation

2.7 Ventilation

All dwellings require ventilation for a number of reasons:

- For the health and comfort of occupants.
- To ensure safe and efficient operation of combustion appliances (e.g. gas boilers) which draw combustion air from within the dwelling.
- To control condensation by the removal of moisture vapour.
- To remove other pollutants and odours.

The main types of purpose-provided ventilation system are:

- Local extraction based on trickle vents and extract fans.
- Whole house ducted systems based on either passive stack ventilation or mechanical ventilation with heat recovery.

2.7.1 Local extraction

Trickle vents

- Simplest method of providing background ventilation.
- Cheap to install, no maintenance required.
- Not usually enough on their own, but can reduce the need to open windows.
- **Not** suitable for high-rise flats due to wind.

Extract fans

- Fitted in kitchen and bathroom on wall, ceiling or through window.
- Optional controls include humidistats (switches fan on automatically when air reaches a set humidity) and timer (fan runs on for a time after being switched off).
- Relatively cheap and easy to maintain.
- Most effective when installed at high level away from the source of fresh air (internal doors and trickle ventilators).
- In the kitchen, ideally combined with a cooker hood.
- The latest low-wattage fans incorporate DC motors and are very energy efficient.
- Single room heat recovery ventilators (SRHRVs) are supply and extract fans combined, which recover heat from the extracted, warm air and use it to warm up the incoming air. Thus, they provide rapid ventilation without the associated heat loss.

Extract fans should not be fitted in rooms with open-flued heating appliances.



Extract fan

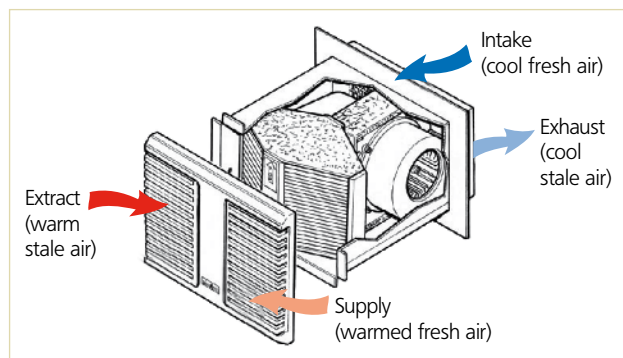

Heat recovery room ventilator

Energy efficiency measures – ventilation

2.7.2 Whole house ducted systems

Whole house passive stack ventilation (PSV)

- Extract ducts run upwards from ceiling grilles in the kitchen or bathroom to the outside through the roof, with fresh air coming in through trickle vents.
- PSV removes moist air continuously without mechanical action.
- It works because of a pressure difference between outside and inside the house.
- Grilles and ductwork need regular cleaning to remove dust.
- Installation is fairly simple.
- It is much quieter than extract fans but boxing for ductwork may be considered unsightly and take up too much space (ducts are usually 80-125mm in diameter).

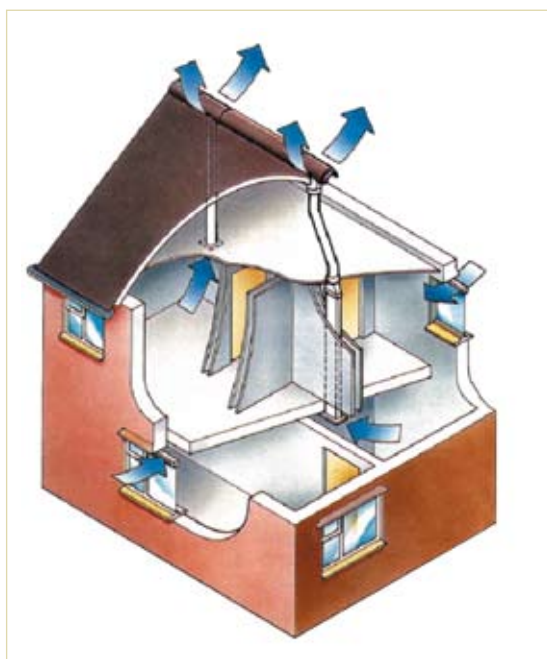

Passive stack ventilation

Two other systems are:

- Centralised mechanical extract.
- Whole house mechanical ventilation with heat recovery.

These systems use extensive ductwork and are not suitable for most refurbishment situations. Please see 'Energy efficient ventilation in housing' (CE124/GPG268) for further information.

'Build tight – ventilate right'

Providing controllable ventilation, via ventilation systems such as extract fans, is essential to maintain healthy living conditions. But in a typical two-storey semi-detached house approximately 16 to 20 per cent of total heat loss is through uncontrolled ventilation (i.e. unwanted gaps and cracks in the building fabric and around poorly fitting service pipes).

Any uncontrolled ventilation can be dealt with by carrying out draught-proofing, sealing unwanted gaps and cracks around services, and therefore reducing any unwanted air leakage. Please see 'Improving airtightness in dwellings' (CE137/GPG224) for further information.

Please note: Extract fans and other purpose-provided ventilation systems must NEVER be disabled.

Further information

- Energy-efficient ventilation in housing (CE124/GPG268)
- Improving air tightness in dwellings (CE137/GPG224)
- Energy efficient refurbishment of existing housing (CE83/GPG155)

Energy efficiency measures – heating systems

2.8 Heating systems

There are three main types of heating systems:

- 'Wet' central heating systems based on boilers and heat emitters (usually radiators).
- Other central heating systems, such as warm-air heating or electric storage heaters.
- Individual room heaters.

An overriding factor which influences running costs and CO₂ emissions is the fuel type used, see graphs (right).

If a new heating system is required it is therefore worth considering switching to a cheaper and more environmentally friendly fuel. Other important factors that influence the running costs and CO₂ emissions are:

- The efficiency of the specific heating system.
- The amount of heat that the system needs to supply to maintain comfortable living temperatures (which will be higher in larger, poorly insulated dwellings).
- The presence of heating controls.
- The occupants' heating requirements and practices.

2.8.1 Central heating boiler systems

There are three main types of central heating boiler.

- Regular boilers (which provide hot water via a separate storage tank).
- Combination boilers (which provide 'instant' hot water at mains pressure).
- Thermal stores (including separate stores and combined primary storage units – 'CPSUs')

Regular boilers or CPSUs are normally used in larger houses; combi boilers are generally used in small houses or large flats because they save space. (They are fed directly from the water main, and hence don't require space for a cylinder.)

Boilers are predominantly run on mains gas, oil or liquified petroleum gas (LPG). Some direct-acting electric boilers and solid fuel boilers are available, but these can be more expensive to run and cannot be recommended where other fuel sources are available.

An off-peak electric system should only be considered for small well-insulated flats.

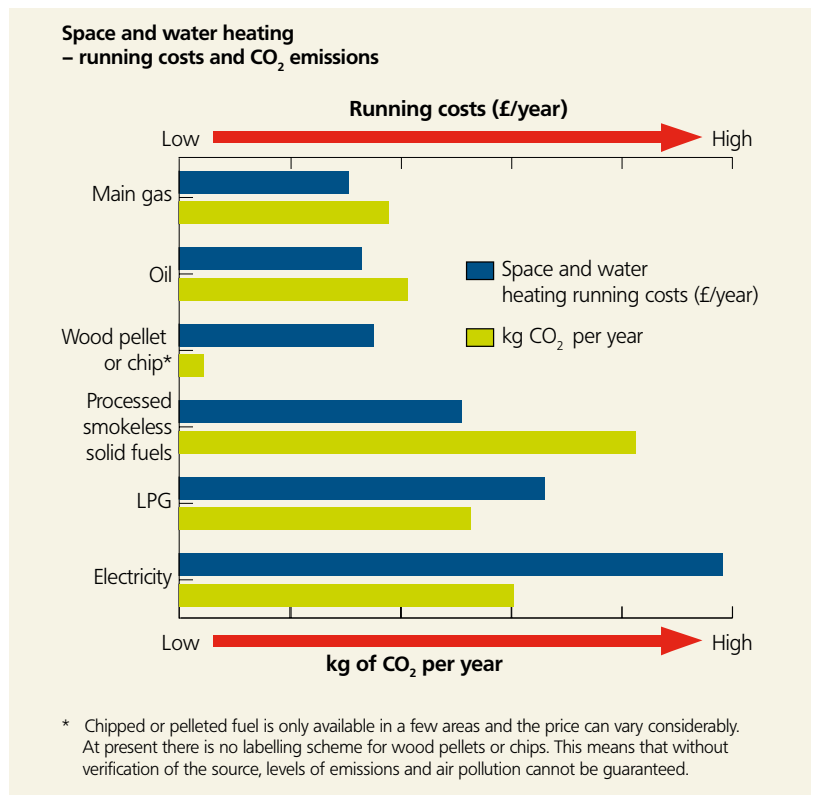

2.8.2 Replacement A-rated condensing boiler

The extra cost of an A-rated boiler, instead of a B, is usually very small (typically £50), therefore it is advisable to purchase an A-rated model.

Savings for a variety of dwellings and fuel types are listed in 'Central Heating Systems Specifications (CHeSS) - Year 2005' (CE51/GIL59).

A-rated condensing boilers:

- Are suitable for a large majority of homes or flats.
- The most efficient type of boiler, with a typical seasonal efficiency of 90 per cent.
- Efficiency remains high even when working at a low level of output, such as only for hot water in summer.
- Need a drainage connection.
- Often have a characteristic 'plume' of water vapour coming from the flue – indicating that the boiler is functioning efficiently.

The presence of the 'energy saving recommended' logo indicates an A-rated condensing boiler (for more information please see page 33).

Energy efficiency measures – heating systems

Why is a condensing boiler so efficient?

Condensing boilers are essentially the same as non-condensing boilers, but they extract more heat from the hot flue gases because they have a larger heat exchanger. This means that the flue gases are cooler, so water vapour is visible in the form of 'pluming'.

Any water that has condensed out of the cooled flue gases is taken away via a condensate drain.



A pluming boiler flue



A condensate drain

Condensing boilers are always more efficient than non-condensing boilers (even when not pluming) because of their larger heat exchanger.

Good savings are achieved when upgrading almost all boilers which are over 15 years old. A new boiler plus the right heating controls can cut fuel bills by 25-35 per cent. If the old boiler is located on an external wall, the change should be relatively straightforward – the new flue and condensate pipes being easy to locate.

Dwellings with an old centrally located boiler (such as a room heater with back boiler) will need a suitable external wall to have a condensing boiler fitted. The heating installer will advise on how to do this.

Radiators or an underfloor distribution system can be used for space heating.

Radiators are:

- A cheaper option.
- Easy to maintain and control.

Underfloor heating is:

- Aesthetically pleasing.
- Provides background heat.
- Offers a small improvement to system efficiency when paired with a condensing boiler.
- Can be difficult to maintain should problems arise.

Choosing a heating installer

Gas heating systems must, by law, be installed and serviced by a heating engineer registered with the Council for Registered Gas Installers (CORGI).

Oil and solid fuel systems should be installed and commissioned by a member of the Oil-Firing Technical Association (OFTEC) or Heating Equipment Testing and Approval Scheme (HETAS) respectively. Otherwise building control approval is required before undertaking any work. Please see 'Relevant organisations and websites' for more information.

Further information

- Central Heating System Specifications (CHeSS – Year 2005) (CE51/GIL59).
- Domestic heating by gas: boiler systems (CE30).
- Domestic heating by oil: boiler systems (CE29).
- Domestic heating by solid fuel: boiler systems (CE47).

Energy efficiency measures – other heating controls

2.9 Boiler heating controls

If a boiler is less than 10 years old, it is probably more economical to invest in upgrading its controls.

Heating controls may be upgraded at any time. The most cost-effective time is when the boiler is being replaced or when carrying out other work on the heating system.

Upgrade heating controls

	Typical
Annual saving	£60-70
Installed cost	around £200
Installed payback	around 3 years

A good control package for a boiler system should include:

- A programmer capable of timing the space heating and hot water separately.
- Room and hot water cylinder thermostats.
- Motorised valves to provide independent control of heating and hot water.
- Controls so that the boiler only operates when required.
- Conversion to a fully pumped system where necessary.

Thermostatic radiator valves (TRVs)

- Are fitted on to individual radiators and have a range of temperature settings.
- Reduce the flow of water to the radiator as the thermostat reaches its set temperature.
- Can be mounted horizontally or vertically.
- Provide lower temperatures for background heating, e.g. in unused rooms.
- TRVs should not be fitted to radiators in rooms where there is a room thermostat. (If they are, the room thermostat will not turn off when it should.)



Room thermostat

- Turns the boiler and heating pump off when the room temperature has reached the required level.
- Normally located in the living room or hallway, about 1.5m up from floor level.
- A room thermostat and programmer can be combined into a single device called a 'programmable room thermostat'.
- Can incorporate a delayed start feature, which delays the start up of the heating system, depending upon how close the room temperature is to the set temperature – this can help make further energy savings.
- Should not be fitted near radiators, in a draughty or sunny location, or in rooms with TRVs or supplementary heating (e.g. room heaters).



Programmer or timeswitch

- Allows the user to set the periods when heating and hot water are required.
- Timeswitches include a dial which is easy to set – allowing space heating and hot water to be on at the same time, or hot water alone, but not heating alone.
- Digital programmers are preferable as they normally allow 7-day timing for both space and hot water.



Zone control

- Particularly cost-effective for larger dwellings.
- Uses two room thermostats linked to a programmer capable of controlling two or more space heating zones.



Energy efficiency measures – other heating controls

2.10 Other central heating systems

Electric storage heating

- Storage heaters are cheap to buy, but expensive to run.
- A storage heater contains heat-retaining blocks that are heated up overnight using off-peak electricity.
- Storage heaters are often supplemented by electric on-peak panel heaters, which are expensive to run.
- Fan-assisted storage heaters are more responsive.

Storage heaters are usually controlled individually using manual or automatic charge control.

Manual charge control

Manual charge control consists of knobs which the user sets to control the amount of heat to be stored in the heater overnight and the rate of heat output. This method requires careful judging by the occupant, otherwise the dwelling can be too hot or too cold depending on the weather conditions.

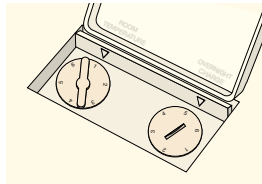

Automatic charge control

Similar to manual charge control, apart from an internal or external temperature sensor that is used to set the amount of heat to be stored automatically.

CELECT-type control

A central control unit replaces the individual controls on each storage heater. This allows for more precise control of individual heaters throughout the dwelling.

Warm air

- Runs on gas (natural or LPG), oil or electricity.
- The heat is distributed around the dwelling using ductwork; individual grilles usually have sliding 'dampeners' which open and close to help balance the heat distribution.
- For gas warm air systems, gas is burnt to warm up a heat exchanger. Air is drawn over the heat exchanger.
- Electric warm air units work on a similar principle as storage heaters – a heat-retaining block is heated overnight using off-peak electricity.
- Replacement units are available, but greater savings will be made by swapping to a condensing boiler where possible.

Individual room heaters

A well-insulated small flat or house may not require a central heating system: one or two efficient room heaters may be adequate. Room heaters can also be used to provide additional background heat, supplementing the main heating system.

To help control the level of heating in different areas (i.e. living room/bedroom) room heaters must be fitted with time and temperature controls.

Individual room heaters may be run on:

- Natural gas.
- Heating oil.
- Bottled gas.
- Electricity.
- Solid fuel.

For efficient heating and reduced running costs it is recommended that room heaters should have a gross efficiency of at least 58 per cent.

Natural gas heaters

Wall convector heaters

- Usually require a balanced flue, so are fitted to an outside wall.
- A full system can be built up room by room.
- Very efficient for a room heater – typically 70 per cent.



Radiant convectors

- Provide radiant and convective heat.
- Decorative fuel-effect fires are typically 20-25 per cent efficient and are totally inset within the fireplace opening. Very little heat is produced and their use is mainly decorative.
- Inset live fuel effect fires are partially inset within the fireplace and flames are usually open. Typically 40 to 70 per cent efficient, depending on the design.
- Flueless fires are individual heaters without a flue and which must have enough fresh air brought into the room from outside for their safe operation (typically 90 per cent efficient).



An inset live fuel-effect fire

Energy efficiency measures – other heating controls

Bottled gas portable heaters

- High running costs.
- High risk of condensation through the production of water vapour (about 1kg of water per kg of liquid gas).

Electric heaters

- Are 100 per cent efficient, but the most expensive when run on full price tariff.
- Fan heaters and bar fires should be used for supplementary heating only.
- Oil-filled radiators should be run on cheap rate electricity tariffs, where possible.
- Panel heaters are often used to supplement storage heaters as part of an electric central heating system; they should have time and thermostatic control.

Solid fuel room heaters and stoves

- Require a storage area for the fuel.
- Dampeners are included which control the combustion air supply.
- Multi-fuel appliances can be run on anthracite, house coal, wood or manufactured coal (e.g. coalite)
- Burning wood from a sustainable source has lower CO₂ emissions.
- Open fires combined with a high output back boiler are around 70 per cent efficient.
- Stoves can include back boilers to provide heating and hot water.
- Open fires without back boilers require the installation of throat restrictors to control the amount of over-fire air being withdrawn from the room and therefore will improve efficiency (least efficient).



Electric theme fire



Automatic wood pellet boiler

Energy efficiency measures – hot water

2.11 Hot water

Hot water consumption can account for a large percentage of total energy use, especially in a modern, well-insulated dwelling.

There are several ways in which hot water can be supplied. The most common forms are:

- Hot water cylinders which are indirectly heated by a boiler or room heater with a back-boiler.
- A combination boiler which directly heats the water.
- Hot water storage cylinders incorporating electric immersion heaters (using on-peak or off-peak electricity).

Dwellings also often contain a variety of other appliances that supply hot water, the most common being electric instantaneous showers and over-sink heaters.

For a discussion of the relative advantages of each system please consult the heating guides referenced at the back of this publication.

If hot water is provided via a combination boiler, CPSU or a storage combination boiler then it is only generally possible to upgrade the water heating when replacing the boiler.

In many cases it is feasible for most of these systems to be supplemented by solar hot water heating. (Please see renewables section of this guide for more information.)

There are two main types of hot water cylinder: vented and un-vented.

Vented cylinders are the most common and are normally fed by a cold water cistern located in the loft.

Un-vented hot water cylinders are becoming more popular – they provide hot water at mains pressure. They also reduce the amount of pipework required and don't need a feed and expansion cistern in the loft. However, un-vented water cylinders must be installed by an accredited person (unlike vented cylinders, where accreditation is not necessary).

Both vented and un-vented cylinders use the same amount of energy.

2.11.1 Hot water cylinder jacket

Typical	
Annual saving	Approx £20
Installed cost	from £10
Installed payback	around 6 months

Hot water cylinders lose heat over time and require the boiler to fire to maintain a suitable temperature – this uses energy and costs money.

- Insulating an uninsulated hot water cylinder is a priority measure.
- Hot water cylinders can be insulated at any time.
- Adding a cylinder jacket is very cost-effective. A jacket fitted to an uninsulated hot water cylinder can save twice its own cost in the first year.
- Any hot water jacket less than 80mm thick should be upgraded.

A variety of differently sized cylinder jackets is available. Jackets should be fitted with belts to fasten snugly around the cylinder, which will reduce heat losses even further.

Insulating the cylinder to a good standard also serves a secondary purpose of reducing the possibility of overheating in the summer.



A well insulated cylinder jacket



Poorly insulated and badly fitted

Energy efficiency measures – hot water

2.11.2 Replacing hot water cylinders

Replacing a defective component such as a leaking hot water cylinder is a good opportunity to specify a high-performance hot water cylinder. A high-performance hot water store (either vented or un-vented) will:

- Have 50-80mm of factory-applied insulation.
- Incorporate a high recovery coil which provides quicker heating of the hot water.
- Improve the overall seasonal efficiency of the heating system.
- Allow for a smaller cylinder to be specified.

When selecting a high-performance hot water cylinder as a replacement, the specification should be verified against the requirements as stated in CHeSS 2005 (CE51).

When replacing the heating system, bear in mind that swapping to a combi boiler or CPSU removes the need to have a new hot water cylinder installed.

Replacement electric storage cylinder

If your water is being heated only by electricity it is desirable to:

- Use a dual immersion and make use of cheaper off-peak electricity tariff.
- Specify a storage vessel that is large enough to supply the hot water demand between off-peak periods.
- Ensure that it is well-insulated to maintain the water temperature throughout the day.

'Energy saving recommended' cylinders are made to a higher specification and meet this requirement – further design advice is given in CHeSS. A volume of 144 litres is recommended for small households (one or two persons) and 210 litres or more for larger households.

Twin immersion heaters, or a dual element single immersion heater, can be installed and connected such that a small quantity of hot water at the top of the vessel is always available because it is heated from the permanent electrical supply (mainly on-peak), but a larger volume (e.g. for baths) is heated during the off-peak periods to save costs.

When replacing a hot water system, adequate controls should also be specified, as appropriate.

Hot water pipe work and controls

Typical	
Annual saving	Approx £10

A standard package of controls can be specified to reduce energy used for hot water, and may consist of the following:

- Where possible, an upgraded programmer or timeclock to allow time and temperature control of the hot water.
- A cylinder thermostat that switches off the boiler when the required temperature is reached (recommended temperature is 60-65°C).
- Insulation for the primary pipework (between the boiler and the hot water cylinder).
- Fully pumped (not gravity fed) hot water cylinders for maximum efficiency.

In addition to insulating any primary pipework it is also worth considering insulating the secondary pipework, between the cylinder and taps. Tanks and pipework in the loft should always be insulated, to prevent freezing and the risk of bursts.

When shopping for a new hot water cylinder and controls, always look for the 'energy saving recommended' logo. It's your guarantee that the product will save energy, cost less to run and help the environment. (Please see page 33 for further information).

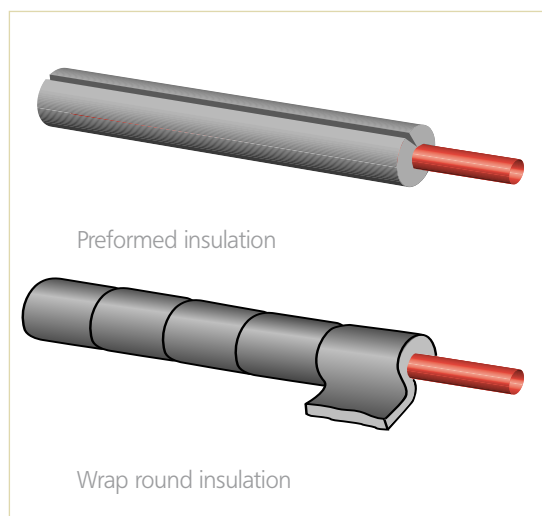

Primary pipework insulation

Energy efficiency measures – lighting

2.12 Lighting

Low-energy lighting, using compact fluorescent lamps (CFLs), can be fitted at any time. Low-energy lighting is most cost-effective when fitted in rooms that are most often used e.g. living room, kitchen and hallway.

In most homes, lighting accounts for 15-20 per cent of the electricity bill.

2.12.1 Compact fluorescent lamps (CFLs)

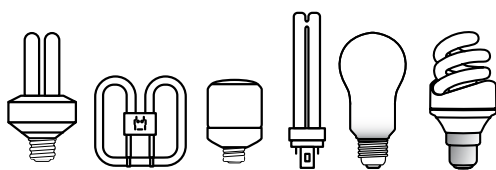

- CFLs last twelve times longer than conventional tungsten lamps.
- They use as little as 25 per cent of the energy used by tungsten bulbs.
- Good quality CFLs with 'high-frequency ballasts' light up instantly, don't flicker, and produce full brightness quickly.
- There are different fittings to suit a variety of lamp types.
- 'Plug-in' CFLs fit in tungsten lamp holders.
- 2- or 4-pin CFLs have light fittings designed specially for them. They are also cheaper to buy.
- 4-pin CFLs can be dimmed (requires specialist equipment).

Replacing a conventional tungsten lamp with a CFL can save up to £9/yr.

The availability of dedicated low energy luminaries has improved hugely in recent years with products available for most applications and styles.

Many of these have 'energy saving recommended' certification. (Please see 33 for more information)

2.12.2 Fluorescent tubes



- Contain high-frequency ballasts as standard, which avoids flicker.
- Dimmable high-frequency ballasts are available.
- Slimline 26mm diameter fluorescent tubes give energy savings of around 8-10 per cent compared with older 38mm fluorescent tube for the same colour rendering, and are cheaper to buy.
- They are suitable for kitchens, workshops and garages.

2.12.3 Tungsten halogen

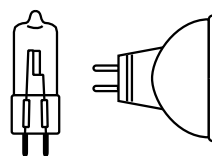

- Only suitable for spotlighting/task lighting, and should not be used for general household lighting.
- They are 50-100 per cent more efficient than standard type bulbs and last about twice as long.
- Often used for security lighting.
- Many tungsten halogen lights operate at 12 volts and require a small transformer.

Further information

- Energy efficient lighting (CE61)
- Low-energy domestic lighting – 'looking good for less' (GPCS441/CE81)
- Cost benefit of lighting (CE56)
- Low-energy domestic lighting (GIL20)

Energy efficiency measures – appliances

2.13 Appliances

Energy-efficient appliances use less electricity and therefore cost less to run. There is ample evidence that energy-efficient appliances are often no more expensive to buy than equivalent appliances that are much less efficient. When buying an appliance, look for the following energy labels.

2.13.1 Energy labelling

In 1995 the European Union introduced a compulsory energy labelling scheme for household appliances, covering refrigerators, freezers and fridge-freezers. This scheme has since been extended to include washing machines, tumble dryers, washer-dryers, dishwashers, electric ovens and lamps. Energy labels are displayed on these products in shops and showrooms, in order to allow potential purchasers to compare their efficiencies.

The energy labels show estimated fuel consumption (based on standard test results) and an energy grading from A to G, where A is the most efficient (for cold appliances, A++ is the most efficient). An A-rated appliance will use approximately half as much electricity as a G-rated appliance.

However, the actual amount of electricity used will depend on how the appliance is used and where it is located. For example, a cold appliance (such as a fridge) that is placed next to a heater or oven will use more energy than one that is sited in a cooler place, so kitchen layout is important to energy efficiency.

Some labels now also provide information on other aspects of the performance of the appliance, e.g. washing performance, water usage per cycle, spin (for washing machines), etc.

A/A+ rated appliances	Typical annual saving (£/yr)*
Fridge freezer (A+)	up to £45
Chest freezer (A+)	£35
Upright freezer (A+)	
Refrigerator (A+)	£20
Washing machine (A)	£10
Dishwasher (A)	£20

* based on an appliance purchased new in 1995 being replaced by an 'energy saving recommended' one. Savings for A++ cold appliances are on average £5/yr greater.

2.13.2 Energy saving recommended

The Energy Saving Trust manages a labelling scheme for products of proven energy efficiency. The scheme currently covers:

- Appliances (washing machines, fridges, freezers, dishwashers and tumble dryers)
- Light bulbs and fittings.
- Gas and oil boilers
- Heating controls.
- Loft insulation.
- Cavity wall insulation.
- External wall and dry linings.
- High performance hot water cylinders.
- Windows.

These products carry the 'energy saving recommended' label. Currently endorsed products can be found at www.est.org.uk/recommended



Certification mark

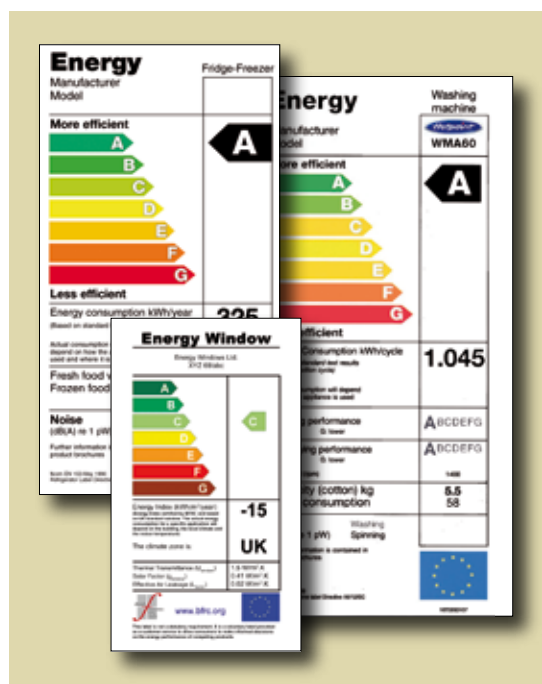

EU Energy labels

3 Renewables

Renewable energy is derived from inexhaustible sources such as the sun, wind, water and plant material. Using renewable energy reduces our dependence on fossil fuel energy sources which contribute to climate change.

Renewable technologies should generally only be considered after carrying out all basic energy efficiency improvements.

Some of the more common renewable energy technologies that you can consider are listed to the right.



Solar hot water evacuated tube



Wind turbine

3.1 Solar water heating (SWH)

- SWH systems use heat from the sun to provide hot water for homes.
- The technology is well developed, with a large choice of equipment to suit many applications.
- Used and sized correctly for the household, it can provide 40-50 per cent of hot water needs over a year.
- One of the most cost-effective, affordable renewable technologies for housing.
- Suitable for use in urban and rural environments.

There are two main collector types: flat plate or evacuated tube.

- Evacuated tubes are more efficient. However, they are also more expensive.
- Flat plate collectors are cheaper but due to their lower efficiency, a larger collector area may be required to yield the same amount of energy.
- Typically a 2-5m² panel is mounted on a south-facing roof.
- Low running costs; and systems normally come with a 10-year warranty.

3.2 Wind turbines

Wind turbines extract energy from the wind using a rotor which usually comprises of two or three blades similar in profile to the wing of an aeroplane. Small-scale wind power is particularly suitable for remote off-grid locations where conventional methods of electricity supply are expensive or impractical.

Wind turbines can provide power for a single dwelling, a business or community building, or even a whole community. The costs of buying and installing a wind turbine will depend on the size of the machine, the application for which it will be used (i.e. stand-alone or grid-connected) and its location.

In stand-alone applications, electrical energy generated by the turbine can be stored in batteries for later use when the wind is not blowing. Turbines can have a lifespan of up to 20 years, but will require servicing regularly to ensure that they are functioning efficiently.

Renewables

3.3 Photovoltaic (PV) panels

PV panels convert sunlight into electricity and, installed on a south-facing roof could, over a year, provide a household with 50-65 per cent of its electricity needs.

- Can be mounted on roofs, on separate structures, or integrated into building components such as cladding panels, roof tiles and glazing.
- The capital cost of PV systems is high, but maintenance and running costs are low compared to grid supplied electricity.
- PV is suitable for use in both urban and rural environments.



PV Panels

3.4 Heat pumps

Heat pumps supply more energy than they consume by extracting heat from their surroundings. Sources include air-to-water, ground-to-water and air-to-air.

- Ground-source heat pumps (GSHP) use electricity to extract heat from the ground by circulating a water/anti-freeze mixture through the pipes.
- These pipes are either laid in horizontal trenches or vertical boreholes.

Heat pumps can achieve a co-efficient of performance of three or more. This means that 3kW of heat energy is delivered for every 1kW of electricity used to power the pump.

These systems have similar running costs to a gas-fired condensing boiler.

- Expensive to install, but cost-effective where mains gas or oil is not available.
- Most cost-effective for dwellings with low heat demand – therefore measures to improve the energy efficiency of existing dwelling should be implemented in retrofit cases.
- Maintenance costs are also likely to be lower than for conventional gas-fired systems.
- Heat pumps can also be used for cooling and can supply domestic hot water.



A ground-source heat pump



An air-source heat pump

Further information

- New and renewable energy technologies for existing housing (CE102)
- Renewable energy in housing (case studies) (CE28)
- Renewable energy sources for homes in urban environments (CE69)
- Renewable energy sources for homes in rural environments (CE70)

4 Building regulations and planning issues

Complying with the building regulations is a separate matter from obtaining planning permission for work to be undertaken.

In most cases the builder, window, heating or insulation contractor will check compliance. Where this is not possible you are advised to check with local authority building control as to whether or not your proposal requires building regulations and/or planning approval.

What works are typically covered under building regulations?

- Improvements or changes to the building fabric, such as CWI.
- Erection or extension of a dwelling.
- Loft or garage conversions.
- Replacement or installation of a new heating system, such as a condensing boiler.
- Replacement windows.
- Hot water systems.
- Fuel-burning appliances of any type.

You should check to see if planning permission is required before:

- Working on the external façade of listed buildings or buildings in a conservation area, national park or area of outstanding natural beauty.
- Undertaking a home extension, conversion or renovation.
- If you want to install a tank to store LPG or oil.
- Installing renewables.

4.1 Building control

Regulations exist primarily to ensure the health and safety of people in and around all types of buildings (i.e. domestic, commercial and industrial). However, they also provide for energy conservation.

Regulations apply to most new buildings or where extensions, alterations and changes of use are being made to existing dwellings (some exceptions may apply).

Building regulations vary across the UK. The following guidance can be consulted to determine the different technical performance requirements, definitions and procedures:

- The Department for Communities and Local Government (DCLG) offers a series of 'approved documents' containing guidance on compliance in England and Wales. Part L deals specifically with the conservation of fuel and power.
- The Scottish Building Standards Agency (SBSA) provides guidance on complying in Scotland through a new system of building standards – Section 6 deals with energy use.
- In Northern Ireland, the building regulations unit of the Department of Finance and Personnel provides guidance via a series of 'Technical Booklets' – Technical Booklet F deals with energy use.

You are advised to check with the area building control team whether or not your proposal requires approval under the regulations.

4.2 Planning permission

Planning permission is generally only required when undertaking external alterations to a dwelling, such as adding external insulation.

Changes to the inside of buildings are generally not covered (with the exception of some listed buildings).

5 Embodied energy

There is a growing urgency to reduce the environmental impacts of human activities.

Energy efficiency initiatives over the last 40 years have reduced the energy consumption of buildings considerably, but action to minimize the impact from construction materials has been relatively slow.

There are two key elements to the energy use of a building. Energy used by occupants to run the building during its lifespan – known as operational energy; and energy used during the manufacture, maintenance and replacement of the components that constitute the building during its lifespan. This is known as embodied energy.

In older buildings operational energy has traditionally represented the major impact. As the energy efficiency standards of modern buildings have been raised the importance of embodied energy has increased.

Where the selection of products and materials directly affect the operational energy, the most

efficient option should be selected. For those looking to maximise environmental benefit, or where products are very similar in terms of operational performance, then embodied energy aspects should also be taken into consideration.

Windows and doors typically contribute between 5-10 per cent of the embodied energy of a building. Although using double glazing increases the embodied energy of a building, the savings in energy from the improved insulation double glazing provides outweigh this additional impact within a year or so of installation.

Further information

- BR390 The Green Guide to Housing Specification, Anderson and Howard, BRE, 2000.
- Life Cycle Assessment of PVC and of principal competing materials. Commissioned by the European Commission, April 2004.

6 Cost benefit table

Detached house or bungalow	Saving (£/yr)	Typical installed cost (£)	Payback (yrs)	Typical DIY Cost (£)	Payback (yrs)
Cavity wall insulation	£210 - £250	£300	Less than 2 years	-	-
Solid wall insulation (external)	£460 - £560	£2,300	4 - 5	-	-
Solid wall insulation (internal)	£430 - £530	From £40/m ²	-	£1,900	Around 4 years
Loft insulation (new installation)	£210 - £250	£250	Less than 1 year	£330	Less than 2 years
Loft insulation (top up)	£60 - £70	£260	Around 4 years	£250	Around 4 years
Floor insulation	£60 - £70	-	-	£120	Around 2 years
Replacement condensing boiler	£130 - £160	-	-	-	-
Hot water tank insulation	Approx £20	-	-	£10	Around 6 months
Full heating control package	£70 - £90	£200	2 - 3	-	-
Draught-stripping	Approx £20	£75	Around 4 years	£45	Around 2 years
Lighting (4 x lamps)	£15 - £20	up to £15	Less than 1 year	up to £15	Less than 1 year

Semi-detached or end-of-terrace	Saving (£/yr)	Typical installed cost (£)	Payback (yrs)	Typical DIY Cost (£)	Payback (yrs)
Cavity wall insulation	£130 - £160	£260	Less than 2 years	-	-
Solid wall insulation (external)	£290 - £350	£1,800	5 - 6	-	-
Solid wall insulation (internal)	£270 - £340	From £40/m ²	- - -	£1,200	Around 4 years
Loft insulation (new installation)	£180 - £220	£230	Around 1 year	£290	Less than 2 years
Loft insulation (top up)	£50 - £60	£240	4 - 5	£215	Around 4 years
Floor insulation	£40 - £50	-	-	£100	Less than 2 years
Replacement condensing boiler	£100 - £120	-	-	-	-
Hot water tank insulation	Approx £20	-	-	£10	Around 6 months
Full heating control package	£60 - £70	£200	Around 3 years	-	-
Draught-stripping	Approx £20	£75	Around 4 years	£45	Around 2 years
Lighting (4 x lamps)	£15 - £20	up to £15	Less than 1 year	up to £15	Less than 1 year

Cost benefit table

Mid-terraced	Saving (£/yr)	Typical installed cost (£)	Payback (yrs)	Typical DIY Cost (£)	Payback (yrs)
Cavity wall insulation	£70 - £80	£250	3 - 4	-	-
Solid wall insulation (external)	£150 - £180	£1,300	7 - 9	-	-
Solid wall insulation (internal)	£140 - £170	From £40/m ²	- - -	£600	Around 4 years
Loft insulation (new installation)	£150 - £190	£230	1 - 2	£255	Less than 2 years
Loft insulation (top up)	£40 - £50	£240	5 - 6	£190	4 - 5
Floor insulation	Approx £20	-	-	£95	Less than 5 years
Replacement condensing boiler	£70 - £80	-	-	-	-
Hot water tank insulation	Approx £20	-	-	£10	Around 6 months
Full heating control package	£50 - £60	£200	Around 3 years	-	-
Draught-stripping	£15 - £20	£75	4 - 5	£45	2 - 3
Lighting (4 x lamps)	£15 - £20	up to £15	Less than 1 year	up to £15	Less than 1 year

Flats	Saving (£/yr)	Typical installed cost (£)	Payback (yrs)	Typical DIY Cost (£)	Payback (yrs)
Cavity wall insulation	£40 - £50	£230	5 - 6	-	-
Solid wall insulation (external)	£100 - £120	£1,000	8 - 10	-	-
Solid wall insulation (internal)	£90 - £110	From £40/m ²	-	£700	6 - 8
Loft insulation (new installation)	£250 - £310	£220	Less than 1 year	£200	Less than 1 year
Loft insulation (top up)	£70 - £80	£240	Around 3 years	£145	Around 2 years
Floor insulation	Approx £30	-	-	£70	Around 2 years
Replacement condensing boiler	£50 - £60	-	-	-	-
Hot water tank insulation	Approx £20	-	-	£10	Around 6 months
Full heating control package	£40 - £50	£200	4 - 5	-	-
Draught-stripping	Around £10	£75	Around 8 years	£45	Around 5 years
Lighting (4 x lamps)	£15 - £20	up to £15	Less than 1 year	up to £15	Less than 1 year

The figures in this table are only an indication of costs; actual quotations could be higher or lower.

Notes

- 1^o The costs and savings figures will vary according to the size of the house, its location, the measure (if appropriate), fuel, heating system and the materials used.
- 2^o Energy savings are estimated from a range of standard house types with gas heating and a standard occupancy. Actual savings depend on individual circumstances. Remember that some of the benefit may be taken in improved comfort.
- 3^o DIY costs are for these measures where an average level of DIY skill is required. If in doubt about any aspect of the installation skills required consult an appropriately qualified person.

4^o The installed costs per measure for insulation measures is intended to be representative of the typical cost to the householder in a subsidised scheme eg Energy Efficiency Commitment (EEC), calculated as an average across schemes as at May 2006.

- 5^o External wall insulation costs are marginal costs, assuming remedial work is being undertaken on the walls at the time of installation.
- 6^o Heating control costs assume the additional costs for installation when an installer is at the premises working on the heating system.
- 7^o Lighting savings assume a mixture of wattages replaced and hours of use.
- 8^o DIY Cost of Floor insulation assumes the material cost of the insulation required only.
- 9^o Savings given for condensing boilers assume that the installation of condensing boilers are mandatory and hence no additional cost against a minimum standard building regulations compliant boiler

7 Relevant organisations and websites

Energy efficiency advice and grant information

The Energy Saving Trust manages a UK-wide network of Energy Efficiency Advice Centres (EEACs). Call 0800 512 012 to find your local EEAC or visit www.est.org.uk/myhome

Insulation

Cavity Insulation Guarantee Agency (CIGA)
Tel: 01525 853 300
www.ciga.co.uk

National Insulation Association (NIA)
Tel: 01525 383 313
www.insulationassociation.org.uk

British Polyurethane Foam Contractors Association (BUFCA)
Tel: 01428 654 011
www.bufca.co.uk

Insulated Render and Cladding Association (INCA)
Tel: 01428 654 011
www.inca-ltd.org.uk

Glazing

Glass and Glazing Federation
Tel: 0870 042 4255
www.ggf.org.uk

Fenestration Self-Assessment Scheme
Tel: 0870 780 2028
www.fensa.co.uk

British Fenestration Rating Council (BFRC)
Tel: 08700 278 494
www.bfrc.org

Draught-proofing

National Insulation Association
Tel: 01525 383 313
www.insulationassociation.org.uk

Draught Proofing Advisory Association Limited
Tel: 01428 654 011
www.dpaa-association.org.uk

Heating and hot water

CORGI (Council of Registered Gas Installers)
Tel: 0870 401 2200
www.corgi-gas-safety.com

HHIC (Heating and Hot water Information Council)
Tel: 0845 600 2200
www.centralheating.co.uk

OFTEC (Oil-Firing Technical Association)
Tel: 0845 658 5080
www.oftec.org

Heating Efficiency Testing and Advisory Service Ltd (HETAS Ltd)
Tel: 01242 673 257
www.hetas.co.uk

The Solid Fuel Association
Tel: 0845 601 4406
www.solidfuel.co.uk

The British Electrotechnical and Allied Manufacturers' Association
Tel: 020 7793 3000
www.beama.org.uk

Energy Advice Handbook

The energy advice handbook is an essential reference book for energy advisors and those interested in domestic energy issues.
Tel: 01457 873 610
www.energyinform.co.uk

Embodied energy

BR390 The Green Guide to Housing Specification, Anderson and Howard, BRE, 2000

Life Cycle Assessment of PVC and of principal competing materials. Commissioned by the European Commission, April 2004.

8 Further reading

The Energy Saving Trust sets energy efficiency standards that go beyond building regulations for use in the design, construction and refurbishment of homes. These standards provide an integrated package of measures covering fabric, ventilation, heating, lighting and hot water systems for all aspects of new build and renovation. Free resources – including best practice guides, training seminars, technical advice and online tools – are available to help meet these standards.

The following publications can be obtained free of charge by telephoning the Energy Saving Trust on 0845 120 7799 or by visiting the website at www.est.org.uk

Whole house

- Energy efficient refurbishment of existing housing (CE83/GPG155).
- Energy efficient refurbishment of existing housing – case studies (CE104/GPCS418).
- Refurbishment site guidance for solid-wall houses (CE184/GPG294).
- Energy efficient historic homes – case studies (CE138).

Home conversion and extensions

- Energy efficient domestic extensions (CE122).
- Energy efficient loft conversion (CE120).
- Energy efficient garage conversions (CE121).

Insulation

- Effective use of insulation in dwellings (CE23).
- Insulation materials chart – thermal properties and environmental ratings (CE71).
- Cavity wall insulation in existing housing (CE16/GPG26)
- Cavity wall insulation: unlocking the potential in existing dwellings (GIL23).
- Internal wall insulation in existing housing (CE17/GPG138).
- External insulation systems for walls of dwellings (CE118/GPG293).
- Advanced insulation in housing refurbishment (CE97).

Glazing

- Benefits of best practice: Windows (CE14).
- Windows for new and existing housing (CE66).

Ventilation

- Energy-efficient ventilation in housing (GPG268).
- Improving air tightness in dwellings (CE137/GPG224).

Heating

- Central Heating System Specifications (CHeSS) – Year 2005 (CE51/GIL59).
- Domestic heating by gas: boiler systems (CE30).
- Domestic heating by oil: boiler systems (CE29).
- Domestic heating by solid fuel: boiler systems (CE47).
- Domestic heating by electricity (GPG345).

Lighting

- Energy efficient lighting (CE61).
- Low energy domestic lighting – looking good for less (CE81/GPCS441).
- Cost Benefit of Lighting (CE56).
- Low energy domestic lighting (GIL20).

Renewable energy

- New and renewable energy technologies for existing housing (CE102).
- Renewable energy in existing homes – case studies (CE191).
- Renewable energy sources for homes in urban environments (CE69).
- Renewable energy sources for homes in rural environments (CE70).

Frequently asked questions

- Energy efficiency – frequently asked questions (CE126).



energy saving trust™

Energy Saving Trust, 21 Dartmouth Street, London SW1H 9BP Tel 0845 120 7799 Fax 0845 120 7789
bestpractice@est.org.uk www.est.org.uk/housingbuildings

CE101 © Energy Saving Trust 1996. Revised 2002. Revised June 2006 E&OE

This publication (including any drawings forming part of it) is intended for general guidance only and not as a substitute for the application of professional expertise. Anyone using this publication (including any drawings forming part of it) must make their own assessment of the suitability of its content (whether for their own purposes or those of any client or customer), and the Energy Saving Trust cannot accept responsibility for any loss, damage or other liability resulting from such use. So far as the Energy Saving Trust is aware, the information presented in this publication was correct and current at time of last revision. To ensure you have the most up-to-date version, please visit our website: www.est.org.uk/housingbuildings/publications. The contents of this publication may be superseded by statutory requirements or technical advances which arise after the date of publication. It is your responsibility to check latest developments.

All technical information was produced by BRE on behalf of the Energy Saving Trust.

Printed on Revive Silk which contains 75% de-inked post consumer waste and a maximum of 25% mill broke.

